

Design of Web based Remote Embedded Monitoring system

B.Srinivas Raja¹ and G.Srinivas Babu²

¹ DVR & Dr.HS MIC College of Technology , ECE Department, Vijayawada, Andhra Pradesh, India
Email:bsraaja@gmail.com

² DVR & Dr.HS MIC College of Technology, ECE Department, Vijayawada, Andhra Pradesh, India
Email:grrinivasbabu@yahoo.co.in

Abstract— In this paper, we combine the mature technology of Web with the embedded and fully utilize the advantages of both. The System can complete the remote access, monitoring and maintenance operations of equipment through the network and Web browser. Through introducing Internet into control network, it is possible to break through the spatial-temporal restriction of traditional control network and effectively achieve remote sensing, monitoring and real-time controlling for equipments. It has wide application prospect and great popularization value.

Index Terms—Embedded Web, Remote Monitoring System, Java Applet

I. INTRODUCTION

In traditional control network, various control information and status parameters acquired from locale are transmitted and exchanged through different field bus in different application area. The transmission distance always is limited in a certain range. It is hard to achieve remote monitoring function at any time or place.

Integrating Web and embedded technology, this paper realized the embedded equipment monitoring system based on web management. Managers can remote access, monitor and maintenance the on-site equipment through the network and using a Web browser without the limit of region and time. It can realize the inter-access between the heterogeneous equipments.

A web server can be embedded in a device to provide remote access to the device from a web browser. The embedded system can be utilized to serve the embedded web documents, including static and dynamic information about embedded systems, to web browsers. This type of web server is called an Embedded Web Server. An embedded web server is a microcontroller that contains an Internet software suite as well as application code for monitoring and controlling systems. Embedded web servers are integral part of an embedded network and paves way for faster time to market products.

Embedded Web based equipment condition monitoring system directly connects the equipment to network as a node. Using B/S model, it provides the equipment condition information by Web page form for user browsing. The clients do not need to install special software and may monitor the current condition of equipment through browsers. This structure has the following advantages: It truly realized seamless connection between equipment and management. It requires no intermediate gateway conversion; by using of the mature Web technology, it greatly decreases the system building cost; with the development of industrial Ethernet technology, the real-time performance of system is improved further.

II. THE FUNCTION DESIGN OF REMOTE MONITORING SYSTEM

The function of Web-based equipment monitoring system is to collect real-time data information of the on-site equipment, publish it through a Web form, and remote send the data in the form of the user-defined data transmission style. It should provide flexible rich remote monitoring and diagnosis function combining the configuration software based on standard browser.

Monitoring system includes Dynamic publishing real-time data and historical data, Remote parameter setting and real-time control, Access level setting and authority authentication, Multi services supporting.[2]

III. THE SYSTEM ARCHITECTURE

As shown in Figure 1, the remote monitoring system consists of three layers: the locale equipments layer, embedded web server layer and web-based remote monitoring layer. The locale equipment layer is the basis of the remote monitoring system. In this layer, all of equipments are connected to the embedded web server through serial bus. Each of equipment realizes two functions: (1) transfer real time detection data or equipment status to embedded web server (2) implement relevant operation according to commands sent from embedded web server. The web-based remote monitoring layer includes PC or some other remote workstations on Internet /intranet. The embedded web server Layer, as a central node of the whole system, lies between the locale equipments layer and remote monitoring layer. It communicates with all locale

equipments by RS485 protocol and realizes the data collection function. On the other hand, it maintains the communication with remote workstations through TCP/IP network protocol and charges the responsibilities to exchange data with web page embedded Java Applet. [1]

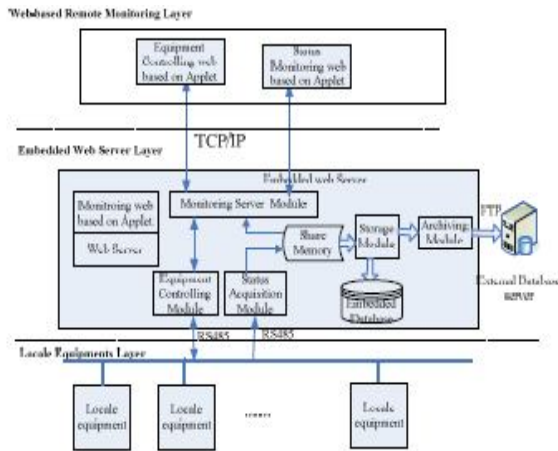

Figure 1. The architecture diagram of embedded remote monitoring system based on Internet

The application scenes of remote monitoring system generally lie in two aspects: equipment controlling and status monitoring. The detailed workflow of them may be simply introduced respectively as follows. The workflow of equipment controlling: (1) Remote users click the command button on Applet and send control command to Monitoring Server Module. (2) Monitoring Server Module resolves the command string and then invokes Equipment Controlling Module to implement specific operation. The workflow of status monitoring: (1) Remote users transmit access request to Monitoring Server Module and then wait for replies continuously. (2) Status Acquisition Module gathers real-time status information from all locale equipments periodically and then sends message to Monitoring Server Module. (3) Once receiving a new message, Monitoring Server Module transmits different status information to relevant applet embedded into web. (4) The applet displays the real-time status information in the browser.

IV. THE DESIGN OF EMBEDDED WEB SERVER

Embedded system is a kind of special computer system which has limited resources and functions. To implement Web server in embedded system is characteristic of itself.

Through providing Web-based graphical management interface for the Internet or LAN users, it eliminated the special client management software and realized unified management of various equipments in

the network. Through existing public communications networks, without geographical restrictions, using a standard Web browser, Users can directly access to the Web server in embedded devices and performance remote monitoring, diagnosis and maintenance of all nodes on the network.

Embedded web server gathers real-time status and then delivers them to the external database server. This method can easily make use of database management software installed on database server to implement data storage and management. Nevertheless, that happens at the cost of low real-time response capacity because of frequent data interaction between the embedded server and external database server. Figure 2. explains the structure of embedded web system

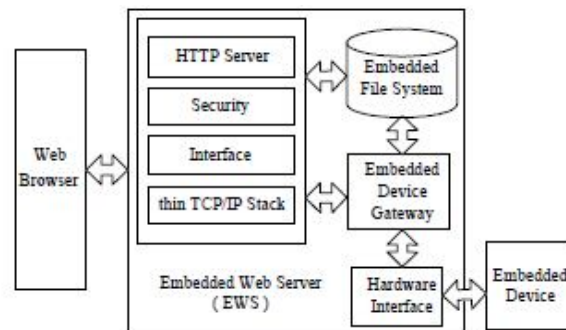

Figure 2. The EWS software architecture

Embedded database management software transplanted in embedded web server is responsible for data storage and management. Embedded database management software has some characteristics suitable for embedded application environment. First of all, it always has small size, so it can be transplanted and used in resource-limited embedded environment. For another, its process-driven access mode can efficiently avoid additional consumption caused by process communication. Data dump should be considered, or the performance of database accesses will gradually go down along with the data expansion.

V. THIN TCP/IP PROTOCOL STACK

The EI technology effectively solves the interconnection problems of the devices and the Internet. The devices can be accessed and controlled remotely using a standard Web browser. How to embed a TCP/IP Web server in devices to make them manageable over the Internet is the key technology. The traditional TCP/IP protocol stack is complex and need substantive system resources. To implement the TCP/IP protocol stack in the embedded systems based on 8/16-bit MCU/MPU, which is limited by the computing and storage resources, is complicated and a great deal of system resources will be occupied [5][6]. The basic TCP/IP protocols necessary to implement the EWS are showed in Fig. 3.

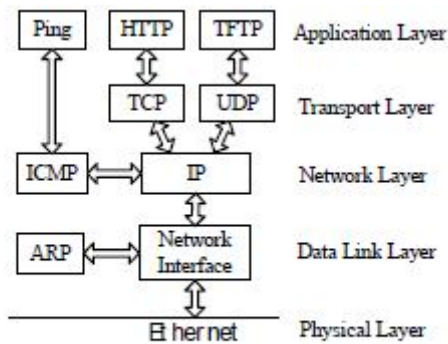

Figure 3. Thin TCP/IP protocol stack

So the price performance ratio must be considered carefully. In this monitoring system, the traditional TCP/IP protocol stack is reduced according to the system requirements. A subset of TCP/IP protocol stack — thin TCP/IP protocol stack is designed and realized according to the thinking of layered framework of network system [7]. It is a hierarchical protocol stack made up of interactive modules each of which provides a specific functionality. This thin TCP/IP protocol stack provides the function of the EWS and enables the embedded devices to have the Internet interface by the way of embedding the EWS in the devices.

This thin TCP/IP protocol stack has five primary layers to facilitate communications from the Web browser to the EWS. It acts as a virtual circuit between the MCU/MPU and the Web browser. A virtual circuit uses packets to transmit data, whereas, a physical circuit creates a direct connection between two nodes. This protocol stack contains applications layer, transport layer, network layer, data link layer and physical layer .

- Application Layer: The browser and the embedded Web server reside at this layer, as does the embedded application code.
- Transport Layer: This layer manages the flow of data between two sites. The transport layer uses two protocols: Transmission Control Protocol (TCP) for reliable packet delivery and User Datagram Protocol (UDP) for much simpler, faster message deliveries with no guarantee of arrival.
- Network Layer: The Internet Protocol (IP) takes the TCP frame and adds the data's source and its destination.
- Data Link Layer: This layer directs the data across the network.
- Physical Layer: This layer is the physical medium over which the data is transmitted

VI. THE COMMUNICATION ANALYSIS

The architecture diagram in the Figure 1.reveals that embedded web server layer communicates with other layers via different communication method and protocol. All equipments are connected with embedded web server by bus structure. The communication between them adopts master and slave access mode. The embedded web server is master machine, as well as locale equipments are slave machines. Each of equipment has a unique address. Its status flag is set as WAIT once reset.

The detailed communication process is described as follows: The embedded web server transmits access address via serial protocol. Each of equipment receives the access address and establish connection with Embedded Web Server only if the access address is same as its. In the communication process, the equipment's status is set as UNWAIT. Until communication process is over, its status will be reset as WAIT.

Monitoring Server Module exchanges information with java Applet embedded into web by TCP/IP [8]. However, data dynamic interactive mechanisms between them are different in two application scenes [5]. In order to simultaneously support the two data dynamic interactive mechanism, the Monitoring Server Module respectively listens to controlling and monitoring requests via controlling port and monitoring port at the same time.

Receiving control request on controlling port, Monitoring Server Module may create a new thread to response. Consequently the new thread analyzes request string to get equipment number and command, and then invokes Equipment Controlling Module to execute. Receiving monitoring request on monitoring port, Monitoring Server Module may establish special socket for communication and store it into correlative queen according to status type. After that, Monitoring Server Module is always in wait status until receiving a new status arriving message from Status Acquisition Module. Once receiving the message, Monitoring Server Module traverses the corresponding queen according to status type and sends information to relevant Applet

VII. THE DESIGN OF DYNAMIC MONITORING WEB PAGE USING JAVA APPLET

Using Java Applet, we can write the executable program embedded in the webpage. The Applet has two methods of acquiring data from the Web server. The first is joining Socket in the Applet and obtain the results after the interaction between Socket and program on the Web server. That must be pay attention that Socket only can interactive with the Socket in Web

server. The second is that Applet can operate the data from the Web server where the own URL on.[2]

Java Applet has some advantageous over CGI [9]. (1)Java Applet is a dependent java program which is embedded into HTML and interpreted by virtual machine in browser. Its development doesn't matter with software and hardware environment of server.(2) Bytecode files, the compile results of Java Applet program on the host machine, only need to download to the target machine. That avoids cross compilation of CGI program.(3)Embedded web server merely exchanges data with Java Applet, but the display task of monitoring web is finished independently by Java Applet on browser. This working mode ensures the load balance between embedded web server and browser. Consequently the design process of applet remote monitoring web in two application scenes will be introduced in detail.

Remote equipment controlling web can be realized using Swing UI Component and event handling mechanism provided by Java language. Controlling button clicked, Java Applet program will response the event and send connection request to the Monitoring Server Module. Once the connection is established, java Applet web transmits the command string including equipment code and controlling command to the Monitoring Server Module.

A Java Applet / ActiveX control embedded in webpage is a HTTP client procedure like the browser. It directly acquires waveform, trends graphics and other data from monitoring node via GET command. Then the data can be analyzed, processed and graphic displayed.

Figure 4 shows the working principle block diagram of Applet/ActiveX controls.



Figure 4 The working principle block diagram of Applet / ActiveX controls.

The browser accesses the embedded Web server to download the webpage which including Java Applet or ActiveX control. Then System gives the domination control to Java applets or ActiveX control. Finally, the embedded controls exchange data with the monitored node directly. For distinguishing with the GET command of browser, we can add “#” or other identifier into the GET command of controls.

VIII. CONCLUSION

Embedded Web is a new technology which base on Thin-server and fat-client model. This paper proposes the architecture of embedded remote monitoring system based on Internet and discusses some key problems in detail. Because the system adopts embedded web server as a central monitoring node, the system is provided with not only excellent cost performance but also running steadily and reliably. Therefore,remote users can access, control and manage the embedded devices using a standard Web browser over the Internet.Moreover, Utilization of dynamic monitoring web based on Java Applet improves the response capability and brings convenience for complex monitoring web design.

REFERENCES

- [1] Fang Hongping, Fang KangLing ,”The Design of Remote Embedded Monitoring System based on Internet” , 2010 International Conference on Measuring Technology and Mechatronics Automation.
- [2] Yong-tao ZHOU, Xiao-hu CHEN, Xu-ping WANG, Chun-jiang YAO , “Design of Equipment Remote Monitoring System Based on Embedded Web”, 2008 International Conference on Embedded Software and Systems Symposia (ICESS2008)
- [3] Wang Xinxin Chen Yun and Yan Ruzhong.” Implementation of the Web-based Mechanical and Electrical Equipment Remote Monitoring System”, Computer Engineering, 2005(31):231-233.
- [4] R. Gao Yunfeng ,Lu Jingui and Wei Hong,”Realization and applicationof Web database access Agent of oriented Applet”, Computer Engineering and Design,2005,(26):1569-1571.
- [5] Sergio Scaglia, “The Embedded Internet”, Pearson Education Press, 2007.
- [6] B Wojciechowski, T Kowalczyk, W Sakowski, “Design Platform forQuick Integration of an Internet Connectivity into System-on-Chips”.Proceedings of Design and Diagnostics of Electronic Circuits and Systems, 2007, pp.1–5.
- [7] Mo Guan, Guangjie Han, Hai Zhao, “The Embedded Internet Technology Based on a Real-Time Kernel for non-PC Devices”, Proceedings of 2004 IEEE International Conference on Networking, Sensing and Control, Taipei, Taiwan, March, 2004, pp. 343–348.
- [8] Xu Wei, “The Research of Embedded Database of Mass Storage Technology”, Microcomputer Information,2008(24):119-120(inChinese)
- [9] Mo Guan, Wei Wei, Ying Bao,” A Monitoring System Based on Embedded Internet Technology for Embedded Devices”, 2008 International Conference on Computer Science and Software Engineering