

# Intelligent Home Energy Management by Fuzzy Adaptive Control Model for Solar (PV)-Grid/DG Power System in India

S.N. Singh<sup>1</sup> and Snehlata<sup>2</sup>

<sup>1,2</sup>Department of Electronics and Communication Engineering  
N.I.T. Jamshedpur- 831014, India

<sup>1</sup>snsnitjsr@gmail.com <sup>2</sup>snehlatamsr12@gmail.com

**Abstract -** Electricity is essential for all households irrespective of their geographical location. Its demand is increasing day by day due to the rapid population growth and greater use of electricity for better standard of living. As the conventional sources of energy are shrinking, a need has arisen to look for alternative sources of energy with more emphasis on its optimal use. This paper presents design of a sustainable solar (PV) system for an Indian city based residential /community house, integrated with grid/DG, supporting it as supplementary sources, to meet entire energy demand of house. A Fuzzy control system model has been developed to optimize and control flow of power from these sources. This energy requirement is mainly fulfilled from PV energy stored in battery module for critical load of a city located residential house and supplemented by grid/DG for base and peak load. The system has been developed for maximum daily household load energy of 60kWh and can be scaled to any higher value as per requirement of individual/community house ranging from 60kWh/day to 70kWh/day, as per the requirement. The simulation work and its hardware implementation, using intelligent energy management, has resulted in an optimal yield leading to average reduction in cost of electricity by 50% per day or even more.

**Keywords -** Photovoltaic (PV), Diesel Generator (DG), Fuzzy Control (FC) etc.

## I. INTRODUCTION

Green energy, also called regeneration energy, has gained much attention nowadays. Green energy, such as solar energy, water power, wind power, biomass energy, terrestrial heat, tidal energy, etc, can be recycled. Among them, Photovoltaic (PV) solar energy is the most powerful resource that can be used to generate power. PV systems as standalone devices are now the lowest cost option for satisfying most of the basic electrical energy needs of the areas not served by distributed electricity, particularly in the developing countries located in the tropics, where the amount of sunshine is generally high. An autonomous PV power system with battery back-up had been proposed earlier, to provide electrical power in the areas where grid is either not available or a new installation/grid extension is yet to be done [1][2][3]. But this system is not viable for houses located in city/town areas due to the heavy

demand of load energy consumption, resulting in a steep rise in the cost of the PV power system. Hence hybridization of PV power systems were thought and developed as reported by many authors in the past leading to a cost effective system [4][5][6], but in most of the systems, the sustainability feature of power supply from PV sources were not considered.

In the present innovative project work, a hybrid PV power system, integrated with utility (grid) has been proposed for home power supply, incorporating sustainability feature using dual battery storage devices, diesel generators as a stand by source to grid supply. Electricity obtained from this hybrid system is more reliable and more cost effective as compared to the stand alone devices i.e. PV or DG or Grid system.

## II. PV TECHNOLOGY

Photovoltaic (PV) systems involve the direct conversion of sunlight into electricity with no intervening heat engine [7]. PV devices are solid state; therefore, they are rugged and simple in design and require very little maintenance. PV systems produce no emissions, are reliable, and require minimal maintenance to operate. They can produce electricity from microwatts to few megawatts. (Figure 1)

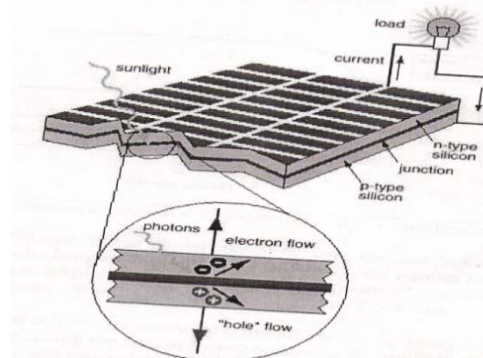

**Fig. 1. Electricity generation by PV Module**

## III. SYSTEM CONFIGURATION AND OPERATION

### (A) Configuration.

The solar (PV) –Grid/DG integrated home power system designed comprises of the following modules (Figure 2(a)):

- PV module
- Battery
- Bi-directional Power Converter
- *Controller unit*
- DG set as a standby power supply source to the grid, etc.

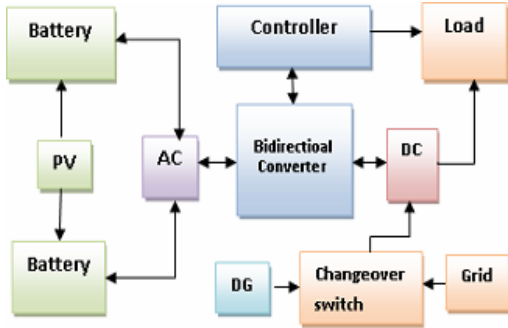

(a)

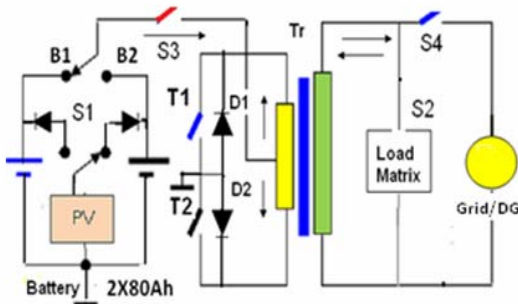

(b)

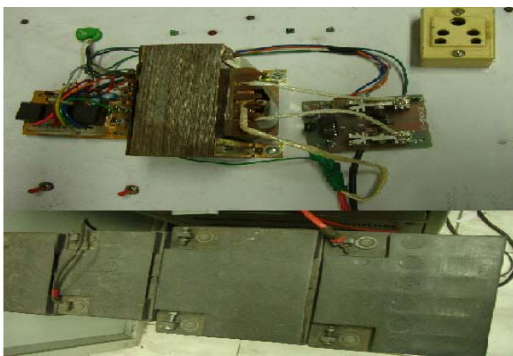

(c)

**Figure 2.(a) Block schematic of a solar power converter with a Grid/DG Set (b) Power circuit Model (c) Prototype system laboratory module**

The system is designed for an urban home load requirement with the specifications as given below:

Load energy : 60-70 Kilowatt-hours over a period of 24 hours

PV size : 2 X 75 Wp, 12 V

Grid supply : 2x Dual 80Ah, 12 V low self discharge inverter grade tubular lead acid battery

Load(s) : Peak: air-conditioner, heater, room-heater, iron, microwave oven, toaster, geyser, etc.

Base: Refrigerator, television, mixer, music system, washing machine, computer, vacuum cleaner, coffee-maker, etc.

Critical: CFL lamps, fans, tube-lights, etc.

Converter : 300W/750 VA, 12VDC ~ 220 V SPWM AC, 50Hz

DG set : Portable LPG 550VA/diesel based 1.5KVA

**(B) Operation.**

The primary source of power supply is the PV energy stored in the battery. Load energy is managed either by the PV system or the grid/DG source. The power converter unit of the PV system takes the low 12V DC voltage as input from PV energy source, stored in one of the battery banks (B1/B2) and controlled through switch S1, as shown in Figure 2(b). It converts the PV energy stored in the other battery bank (B2/B1) into usable 220VAC, 50 Hz 300W/750VA output with the help of a transistorized centre tapped transformer (Tr) based push-pull configured BJT/MOSFET bi-directional converter (inverter) circuit [8]. The controller circuit generates PWM square wave pulses, using IC CD 4047 based 50Hz oscillator, to activate and switch on IRF540 MOSFET/2N3055 transistors T1 and T2 alternatively, producing AC voltage at the output of the secondary of the transformer across the load. The peak load of the household is shared by the grid source. DG set (through switch S4 ) is connected to the load only when the battery reaches either a discharge level of 10.4V or the grid remains absent and the battery does not support the load at that time. The intelligent, adaptive control action of the controller, through the battery and load energy management, monitors and manages to deliver continuous power to the load. Under no- load condition, switch S3 becomes de-activated and thus power loss in the transformer is completely eliminated, resulting in an increase in the efficiency of the inverter. The charging operation is performed by PV source and/or grid /DG source through the converter circuit, comprising of diodes D1 and D2, while transistors T1 and T2 remain off. The PV- Grid /DG dual charging source incorporated in the system prevents the battery from going into deep

discharging and thus the battery never attains a cut-off low voltage of 10.4V.

A proposed prototype of the PV system module (Figure 2(c)) has been developed and installed at a laboratory as per computed maximum load energy requirement of a city based house of Jamshedpur city (India).

**IV. FUZZY CONTROL SYSTEM MODEL**

The control strategy for an integrated power system is a control algorithm for the interaction among various system components. Determining the best condition of operation is the key to achieve the optimum operation. The system controller is designed to perform the following :

- Grid/DG sharing with PV source
- Battery charging operation and
- Cutting-in or cutting-out of the renewable energy sources, etc

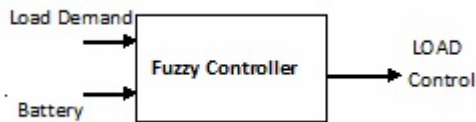

**Fig. 3. A control strategy model of an integrated PV-grid/DG integrated power system**

Figure 3 shows the power flow diagram of the system with input and output control parameters. The inputs of the controller are the parameters of site like unpredictable load power, renewable varying output power stored in battery. The output parameters are the grid/DG connectivity sharing interval and/or switching on of diesel generator and converter for load power and charging operations respectively. A power control strategy is also needed to control the flow of power and to maintain adequate reserves of energy in the battery storage devices. The fuzzy based technique / algorithm [9] has been implemented in the control strategy to achieve optimal sharing of grid power or minimal operation of grid/DG, resulting in reducing the cost of electricity as well as fuel consumption.

**V. FUZZY CONTROL ALGORITHM**

Fuzzy logic control has been used as an intelligent tool to manage the integrated energy sources in such a way that it meets the load requirement under varying load conditions. The system is comprised of a PV module, a diesel generator, bi-directional inverter and an energy storage battery device. The procedures in making the control designs are setting the constraints, assigning the linguistic variables and setting the rules for the controller. Solar radiations and load(s) are the areas that affect the studied outputs and hence, load

demand and the solar (PV) energy stored in battery are considered to be the input variables. The output variables of this controller are the adaptive duty cycle i.e. sharing time interval of grid/DG or turn-on time period of the battery. For low load, the PV energy stored in the battery is sufficient. For medium load, the sharing interval is kept high, whereas for high load, it is kept low, resulting in reduced loss and optimum utilization of energy. Since these input parameters represented by membership function are to be fuzzified, equation (1), the max-min method of fuzzification, is used to set the fuzzy rules of the controller.

$$\mu = (\alpha_1 \square \mu_1) \square (\alpha_2 \square \mu_2) \tag{Eq. (1)}$$

Similarly, since the hybrid energy system cannot respond directly to the fuzzy controls, the fuzzy control sets generated by the fuzzy algorithm have to be changed back by using the method of defuzzification. Subsequently, the approximate centre of gravity (COG) method, supposed to be the most accurate method to get a crisp value is used for the defuzzification, [10] as shown in equation (2).

$$COG = \frac{\sum_{i=1}^n \mu_i A_i(x)}{\sum_{i=1}^n \mu_i A_i(x)} \tag{Eq.(2)}$$

Where  $\mu_i$  = action of the  $i^{th}$  rule would dictate  
 $\mu(i)$ = truth of  $i^{th}$  rule

*Input Variable:*

- Load: Low : trimf (0 15 35)
- Medium : trimf (30 45 65)
- High : trimf (60 75 100)

Battery stored energy status:

- Low : trimf (0 15 35)
- Medium : trimf (30 45 65)
- High : trimf (60 75 100)

*Output variable:*

Grid/DG System:

- DG Low :trapmf (0 0 25 65)
- DG High :trapmf (25 65 100 100)

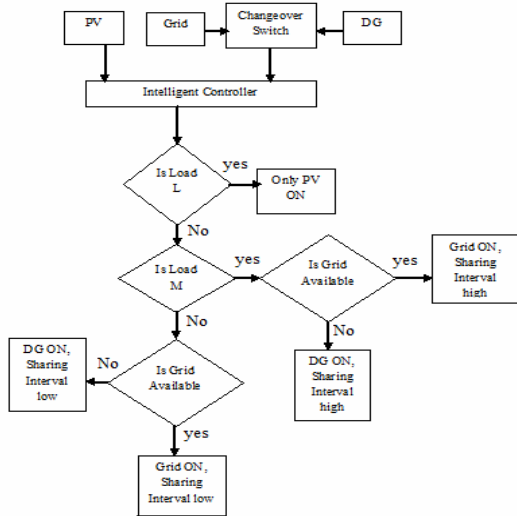

L: Critical load (Low), M: Base load (Medium), H: Peak load (High)

Fig. 4. Flowchart of the system proposed in the paper

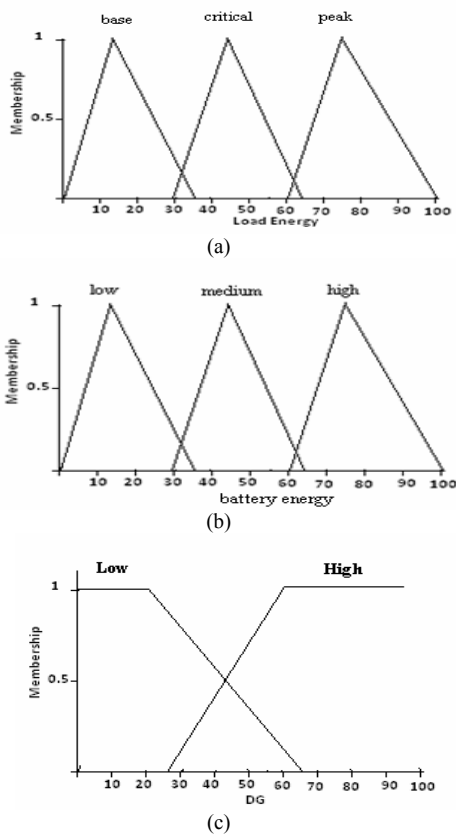

Fig. 5. Membership functions for (a) load energy, (b) battery energy, (c) output i.e. DG/Grid

VI. FUZZY RULE

Knowledge based decisions, based on the input conditions of battery as well as load, have been formulated as a fuzzy rule and shown in Table 1. The output result i.e. P or Z activate the grid/DG to switch it ON or OFF for a sampling period evaluated as a crisp value using Centroid method.

TABLE I: FUZZY RULE

LOAD ENERGY BAT (PV) STORED ENERGY	Low	Medium	High
Low	-	P(1)	Z(2)
Medium	-	P(3)	Z(4)
High	-	P(5)	Z(6)

The simulated results obtained for a typical day are shown in Figure 5. The result is based on the time periods for the use of diesel generator. Here's some rule that explains the working principle of our system based on the fuzzy, it is represented as follows:

TABLE II: RULE BASE

1.	If (B is L) and (R is M)	then O	=	P
2.	If (B is L) and (R is H)	then O	=	Z
3.	If (B is M) and (R is M)	then O	=	P
4.	If (B is M) and (R is H)	then O	=	Z
5.	If (B is H) and (R is M)	then O	=	P
6.	If (B is H) and (R is H)	then O	=	Z

The meanings of the labels designating the names of linguistic values are:

R: load Energy, B : battery stored Energy, S: small, M: medium, H : high, O : grid/DG, Z&P : sharing interval

VII. CASE STUDY

Actual Calculation for operational time in %  
 Load Energy (34) → Low (0.05) & Medium (0.266)  
 Battery energy (64) → Medium (0.05) & Low (0.266)  
 Rules fired are 2, 3, 5 and 6  
 Strength of rule 1 : [ L(0.05) ∩ M(0.05) ] = 0.05  
 Strength of rule 2 : [ L(0.05) ∩ H(0.266) ] = 0.05  
 Strength of rule 3 : [ M(0.266) ∩ M(0.05) ] = 0.05  
 Strength of rule 4 : [ M(0.266) ∩ H(0.266) ] = 0.266  
 CENTROID Method: COG

$$= \frac{(65 * 0.05) + (25 * 0.05) + (65 * 0.05) + (25 * 0.266)}{0.05 + 0.05 + 0.05 + 0.266} = 34.62$$

### VIII. SIMULATION RESULT

The load sensitivity analysis has been carried out to study restoration of load deficit power. The Energy balance equation is governed by equation (3) and equation (4) given below:

(a) Load energy  $\leq$  Critical load  
 Load Energy ( $E_L$ ) = PV energy stored in Battery  $E_{BAT}$  Eq.(3)

(b) Load energy  $\geq$  Base load  
 Load Energy ( $E_L$ ) = grid/ DG power Eq.(4)

Simulations have been carried out using MATLAB, with PV-energy and load energy as inputs, and grid/DG sharing time interval as output, as shown in Figure 6 to Figure 10.

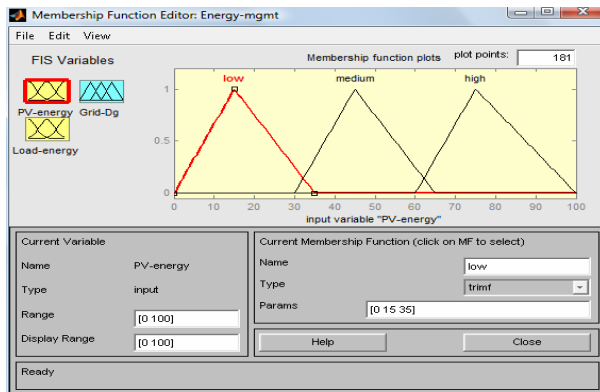

Fig. 6. Membership function for PV-energy

The load energy can be characterized as low, medium and high, depending on whether the load type is critical, base or high.

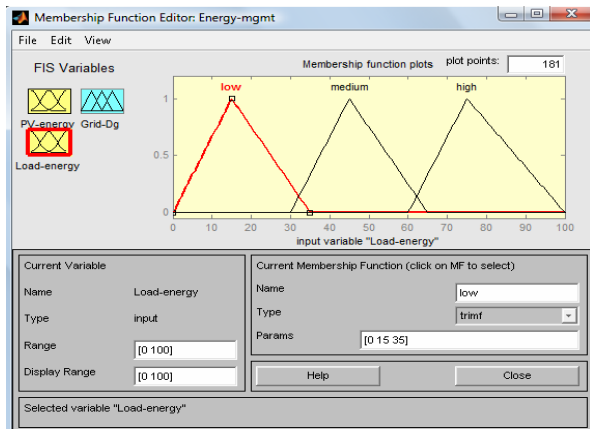

Fig. 7. Membership function for load-energy

The sensitivity analysis for the load energy variation with the changes in energy stored in the battery simulate the condition with fuzzy rules and result in output sharing time-interval of grid/DG for base and peak load with least possible loss.

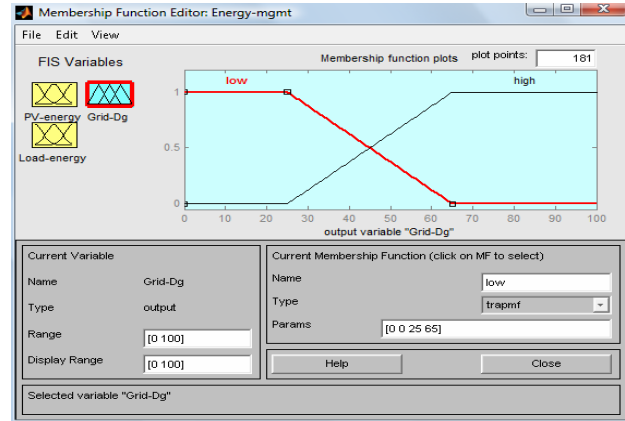

Fig. 8. Membership function for grid/DG time sharing interval i.e. output of the system

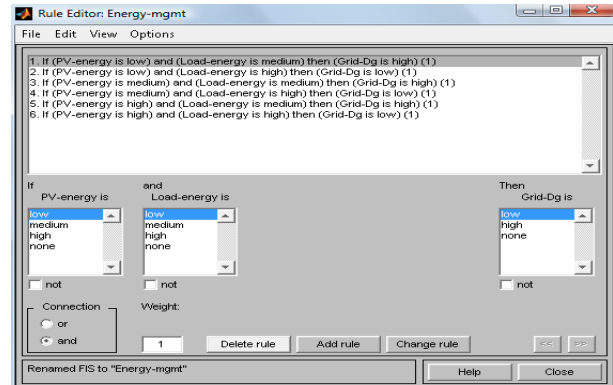

Fig. 9. Fuzzy rules used in simulation

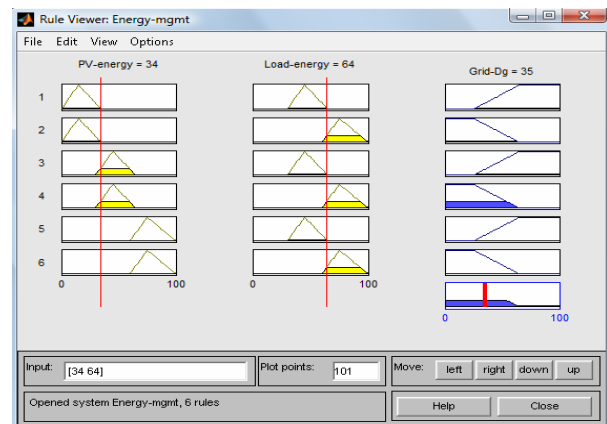

Fig. 10. Rule viewer

### IX. POWER SAVING AND COST OF ELECTRICITY

Cost of saving in electricity due to sharing of load by PV energy (stored in Battery) and grid/DG, is shown in Table 2 during 2008-09. The DG was operated for 600 hours in a year with switching operation of 70 only.

**TABLE III**  
**ELECTRICITY COST REDUCTION DUE TO LOAD SHARING BY PV- GRID/DG SOURCES**

Month	Electricity cost reduction %	Month	Electricity cost reduction %
Jan '08	50	July	50
Feb	56	Aug	60
March	60	Sept	45
April	45	Oct	50
May	35	Nov	45
June	40	Dec' 08	50

### X. CONCLUSION

An integrated solar (PV) - grid / DG system has been proposed for sustainable power generation for the city-based households, where the grid supply is available. A design model of a hybrid PV system, with in-built battery back-up, supplemented by grid supply has been discussed. DG is used as a standby for the grid. The system is adaptive to the load energy, wherein if the load energy is high (peak), the sharing time interval is low, and if the load energy is medium (base), the sharing time interval is high. The simulated results show that introducing a fuzzy logic controller optimizes the sharing of PV system. It also optimizes the fulfillment of peak or medium load power requirement with PV and grid/DG power sharing, resulting in less power loss and consumption of fuel, hence reducing the cost of electricity and the level of pollution. The saving of DG fuel can go up to 30 -100%. The successful implementation of hybrid integrated PV- grid/DG system model has the following outcomes:

- Generating green electricity for meeting the increasing electricity demands of a city-based house, thereby, preserving and protecting the nature.
- Cost effectiveness with reduced size of the PV-system, due to power sharing by grid/DG. Minimal hours of use of DG set results in less fuel consumption and reduces the maintenance as well as operational cost of a diesel generator.

### XI. REFERENCES

- [1] S. N. Singh, Pooja Singh, Swati, Swati Kumari, "Rural Home Energy Management by Fuzzy Control Model for Autonomous Solar(PV)- Diesel Power System in India".
- [2] S.N.Singh, A.K.Singh, "Modeling and dynamics of a PWM sinusoidal Inverter for water pumping system for use in agriculture and household application", *Journal of IEEMA* Jan (2008) pp 114-122.
- [3] S.S.S. Baljit, S.S.S. Ranjit, "Simulation of an off-grid electrical lightening system powered by photovoltaic technology" *ARISE*(2010).
- [4] S.N.Singh, A.K.Singh, "Design and development of Grid-assisted adaptive solar(PV) power converter for water-pumping system in Indian villages", *Journal of ARISE*(2009).
- [5] Banerjee, R. (2008), "Renewable Power generation in India: Establishing Feasible Targets," IASA presentation, 4 June 2008; available: [www.me.iitb.ac.in/~rangan/professional\\_activity/Repower.pdf](http://www.me.iitb.ac.in/~rangan/professional_activity/Repower.pdf).
- [6] King Mongkut's University of Technology Thonburi, "Mini - Grid for Rural Electrification from Hybrid Systems", 2002.
- [7] Georgeta Vidican, Wei Lee Woon, Stuart Madnick, "Measuring Innovation Using Bibliometric Techniques-The Case of Solar Photovoltaic Industry"(2009).
- [8] M.H. Rashid, *Power Electronics : Circuits, devices and applications*, Pearson Education (2004) pp 248-264.
- [9] J.S.R. Jang, C.T. Sun, E. Mizutani, *Neuro-Fuzzy and Soft-Computing: A computational approach to learning and machine intelligence*, Prentice Hall of India(1997) pp 13-63.
- [10] Surekha Bhanot, *Process Control- Principles and Applications*, Oxford University Press (2008) pp 411-441.